

Network Lab

Lab-1

Objectives

- Lab structure orientation.
- Introduction to IP addressing.
- Listing various software packages that ought to be used in this course.

Structure of the lab

Our lab is made up of five networks [LAN A, B, C, D, & E]. Each network is made up of the following:

- Rack consists of Cisco Router, Switch and hub.
- PCs: Each having operating systems and network cards per PC.

1. All the five networks are interconnected and can be used using the patch panel.
2. We use private IP addresses [IP's that are used when we are not connected to the Internet] in our lab. All our IP's belong to Class C addresses. There are 5 Classes of IP addresses [A, B, C, D, and E].
3. Subnet mask is used to get the Network address from an IP address. This is done by doing binary AND operation between the IP address and the subnet mask.
4. The subnet mask we use in our lab is the default mask of Class B [255.255.0.0]. We use this option so that we get same network address for all PCs in our lab and so, they all belong to the same network. When we use routers, we change the subnet mask to 255.255.255.0 so that each LAN belongs to different network.
5. A Linux Server is accessible at 192.168.230.252 and a Windows server is accessible at 192.168.230.250. These are connected to the Instructor Patch Panel.
6. Internet access is handled using **Internet Sharing option at Instructor PC.**

SAMPLE LAN STRUCTURE IN ICS-NETWORK LAB

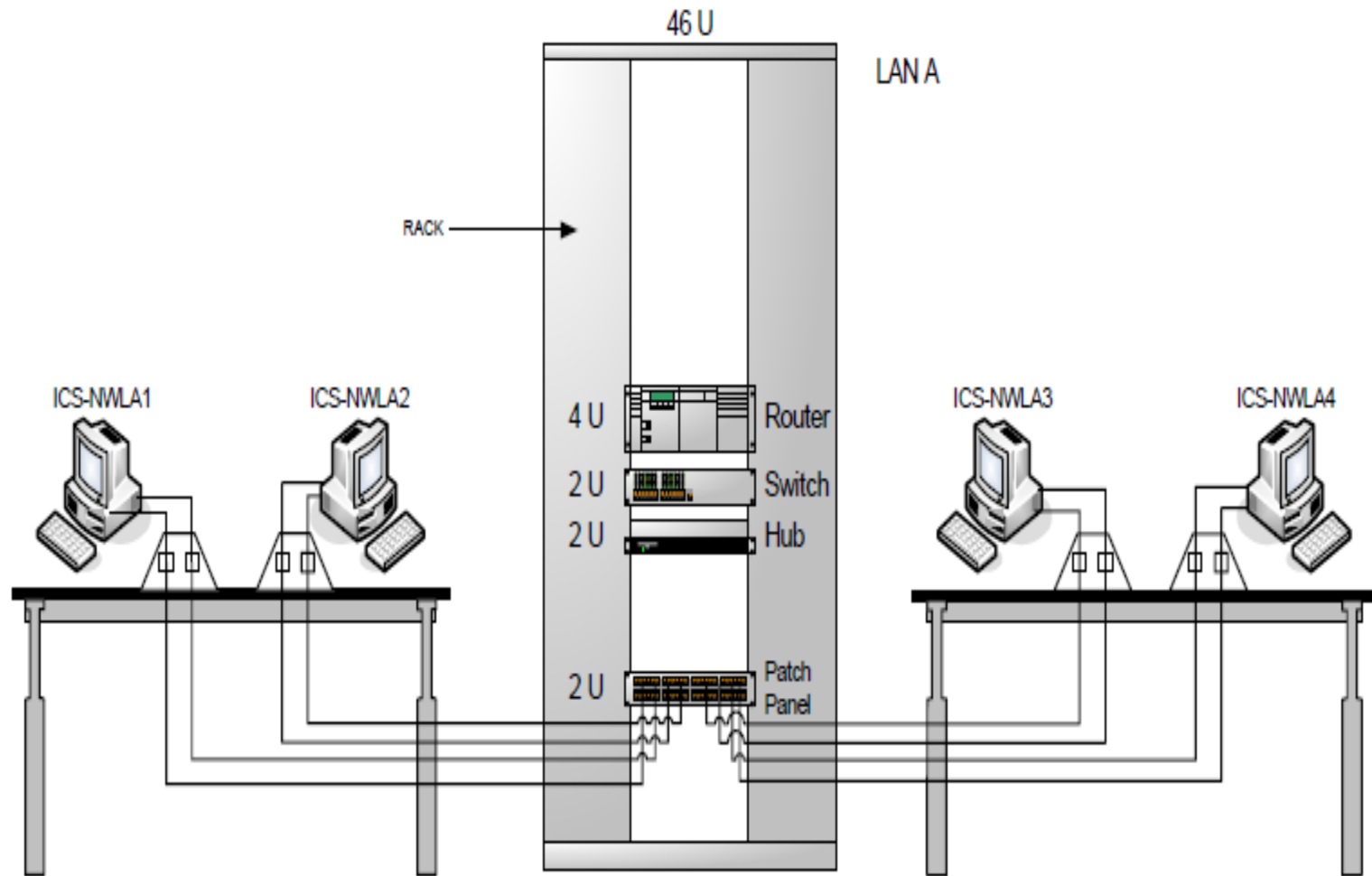

WE HAVE 5 LANS IN OUR LAB [LAN A, B, C, D & E]

Unshielded twisted pair

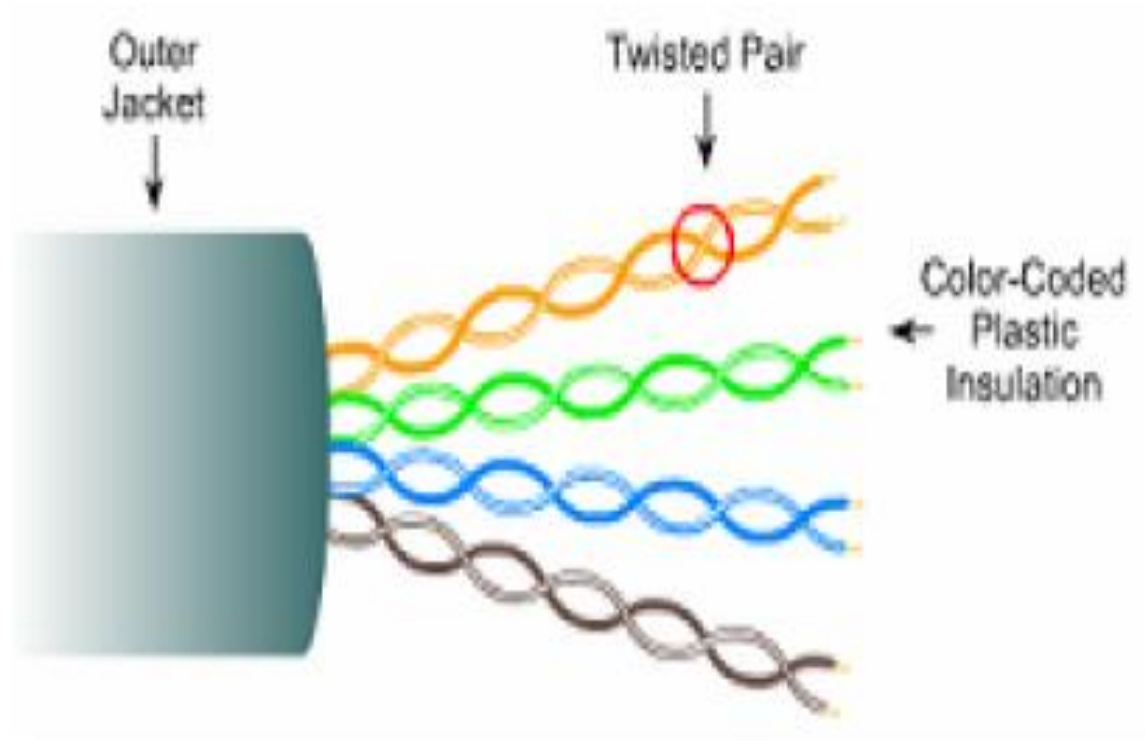

Shielded twisted pair

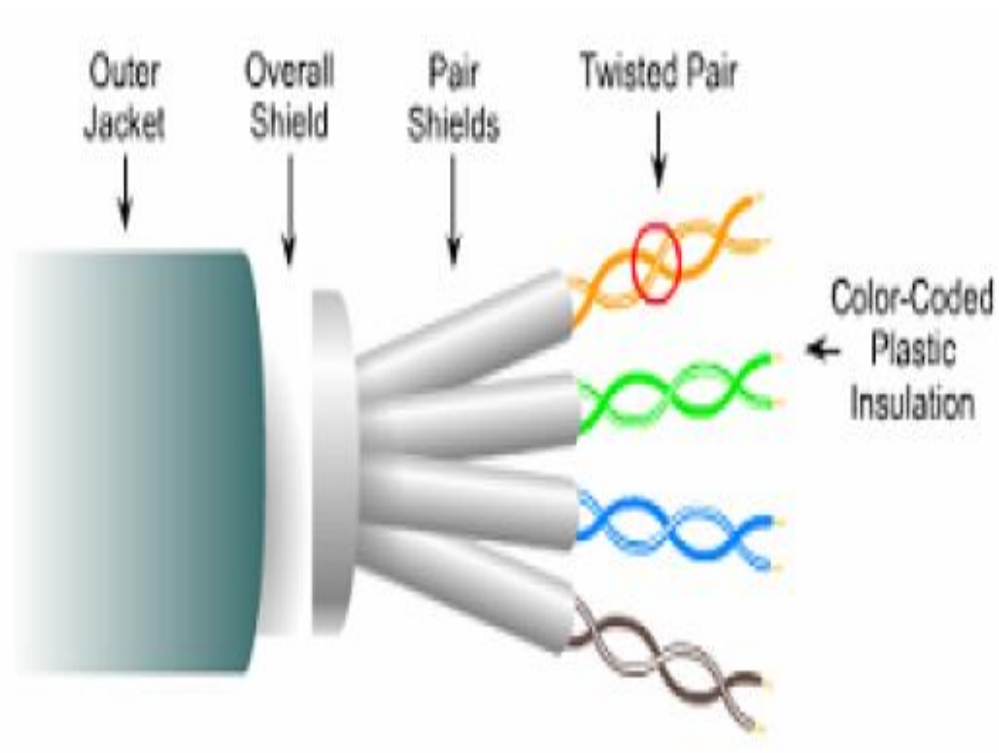

Coaxial cable

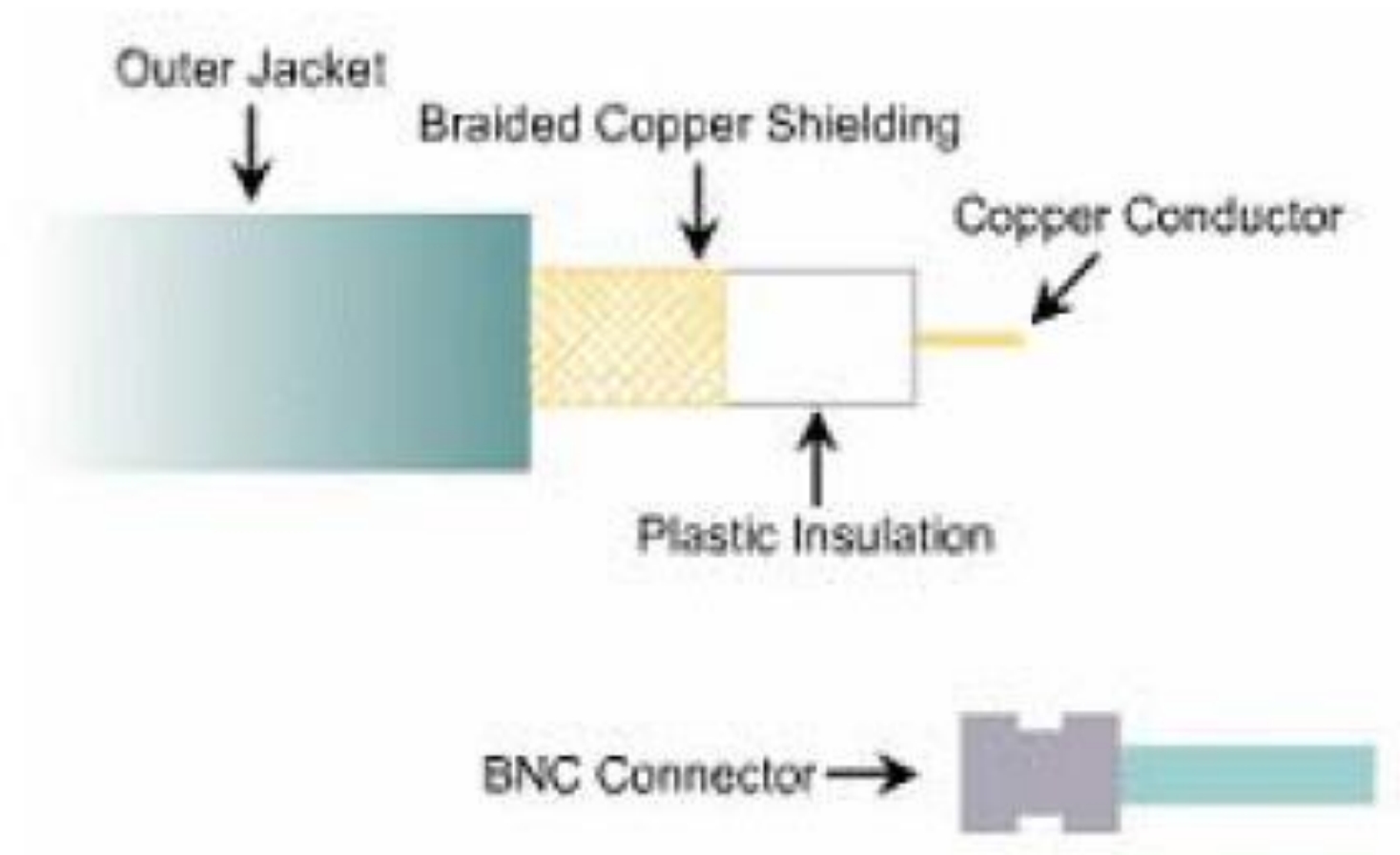

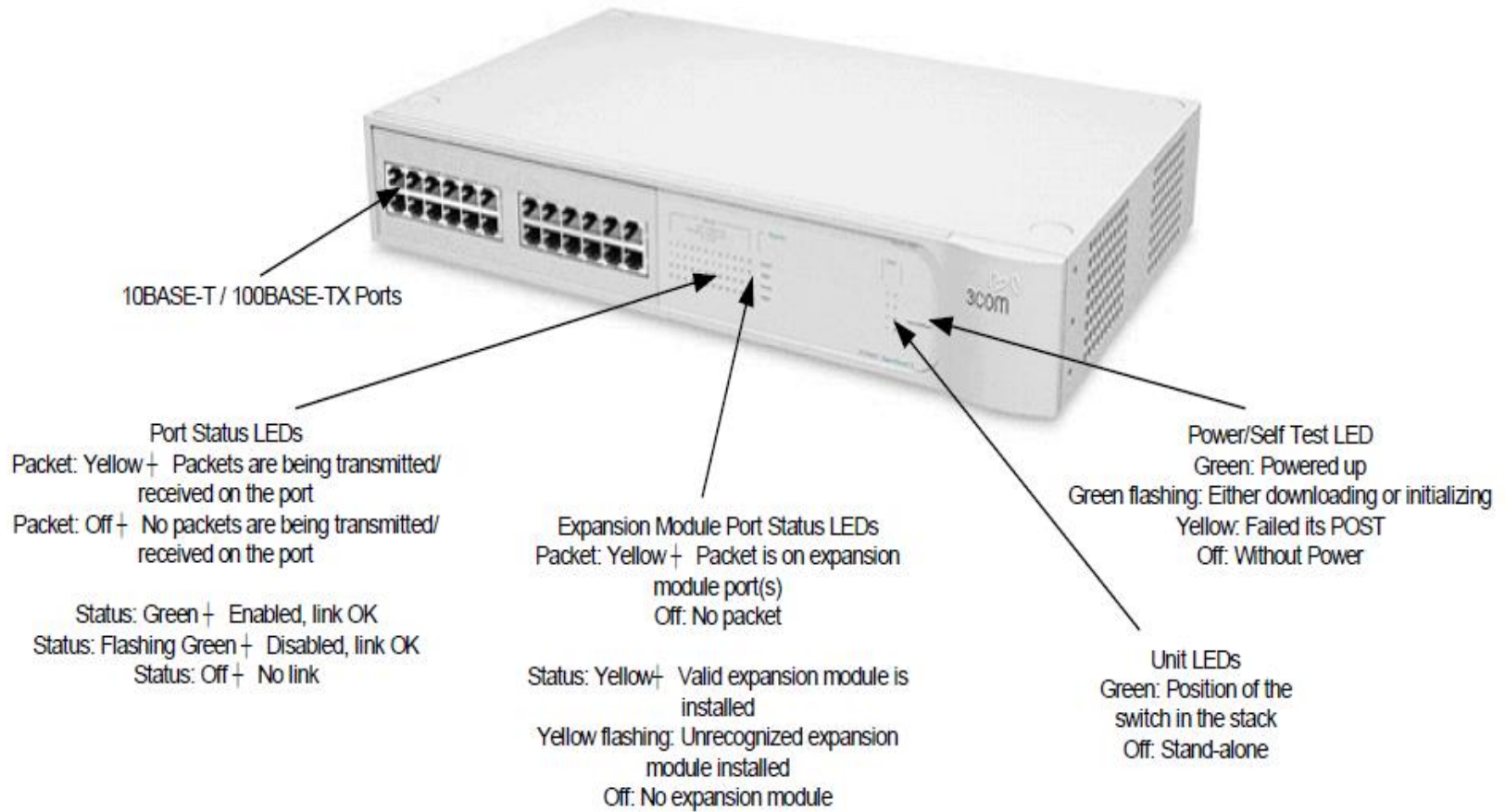
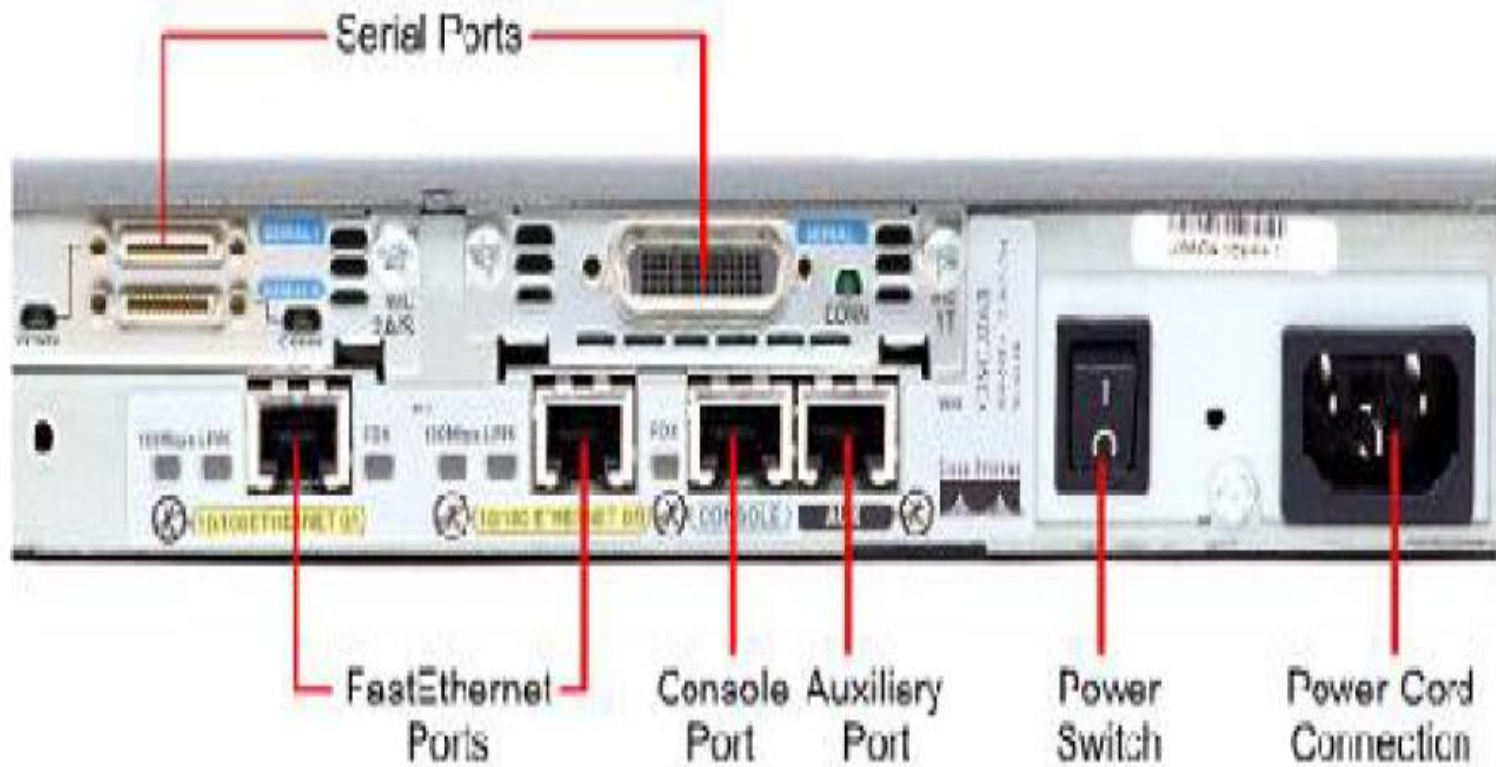

Figure 1.6: Front view of 3COM switch.



ROUTER

Cable connection for network devices

➤ Straight through cable

Green [Pin 1] → Green [Pin 1]
White Green [Pin 2] → White Green [Pin 2]
White Orange [Pin 3] → White Orange [Pin 3]
Blue [Pin 4] → Blue [Pin 4]
White Blue [Pin 5] → White Blue [Pin 5]
Orange [Pin 6] → Orange [Pin 6]
White Brown [Pin 7] → White Brown [Pin 7]
Brown [Pin 8] → Brown [Pin 8]

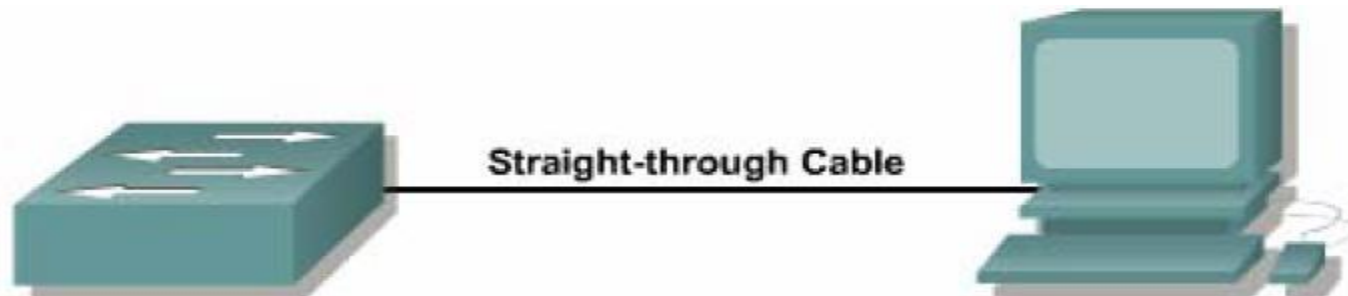

Cross-over cable

Green [Pin 1] → White Orange [Pin 1]
White Green [Pin 2] → Orange [Pin 2]
White Orange [Pin 3] → Green [Pin 3]
Blue [Pin 4] → White Brown [Pin 4]
White Blue [Pin 5] → Brown [Pin 5]
Orange [Pin 6] → White Green [Pin 6]
White Brown [Pin 7] → Blue [Pin 7]
Brown [Pin 8] → White Blue [Pin 8]

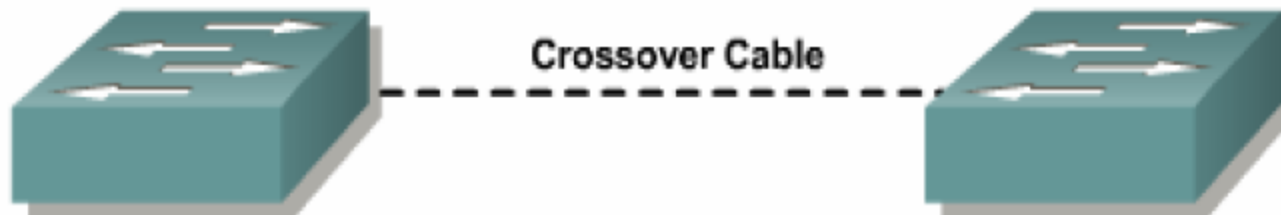

Roll over cable

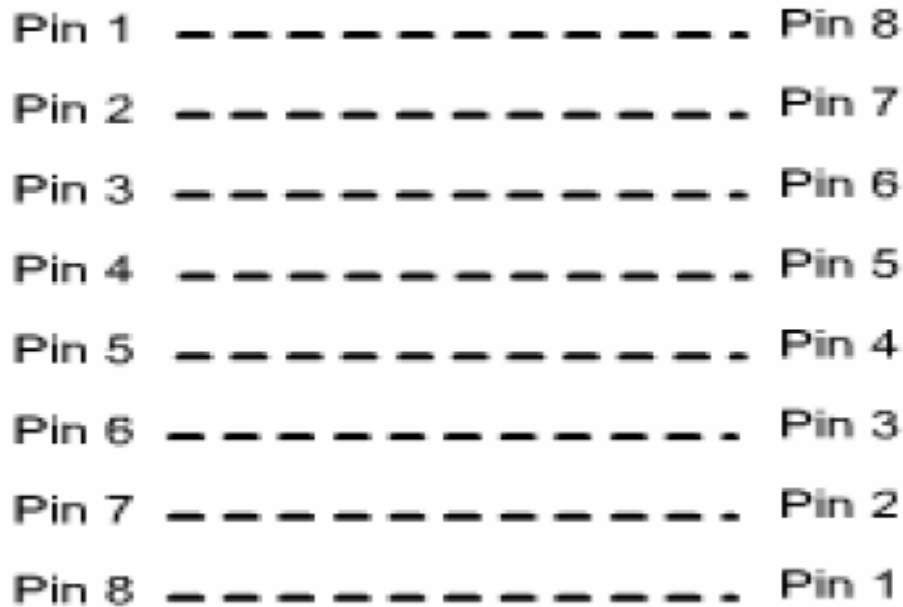

Peer to Peer Connection Networking

Crossover Cable Configure

Equipments:

1. RJ45 Crimping tools
2. RJ45 Connector
3. CAT5 Cable
4. Cable Tester





RJ45 Crimping tools

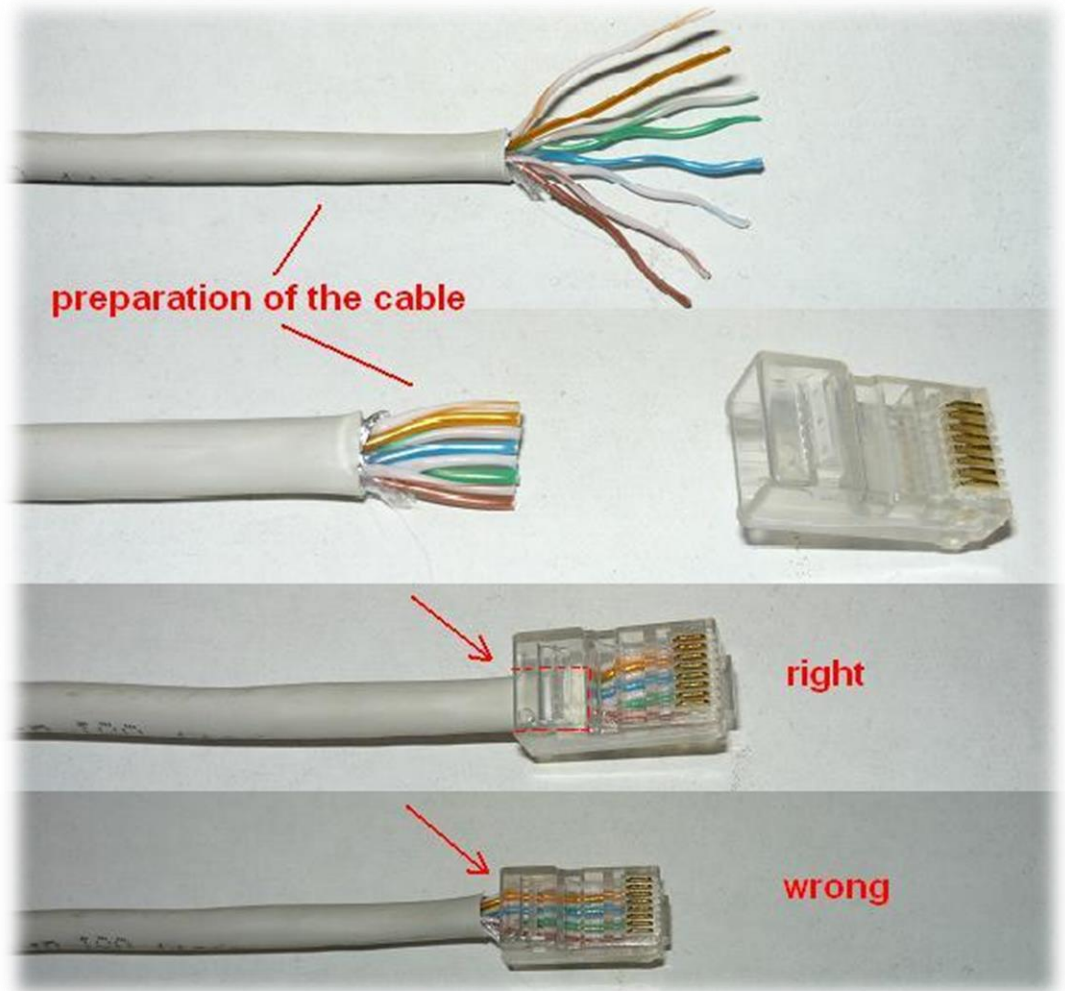
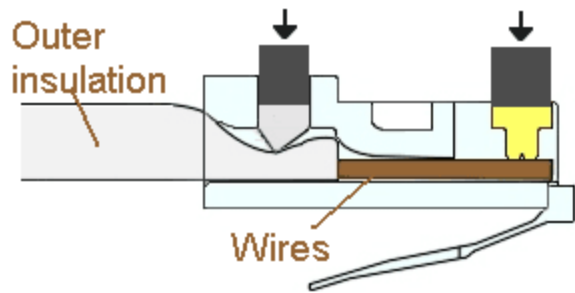

Crossover Cable Configure

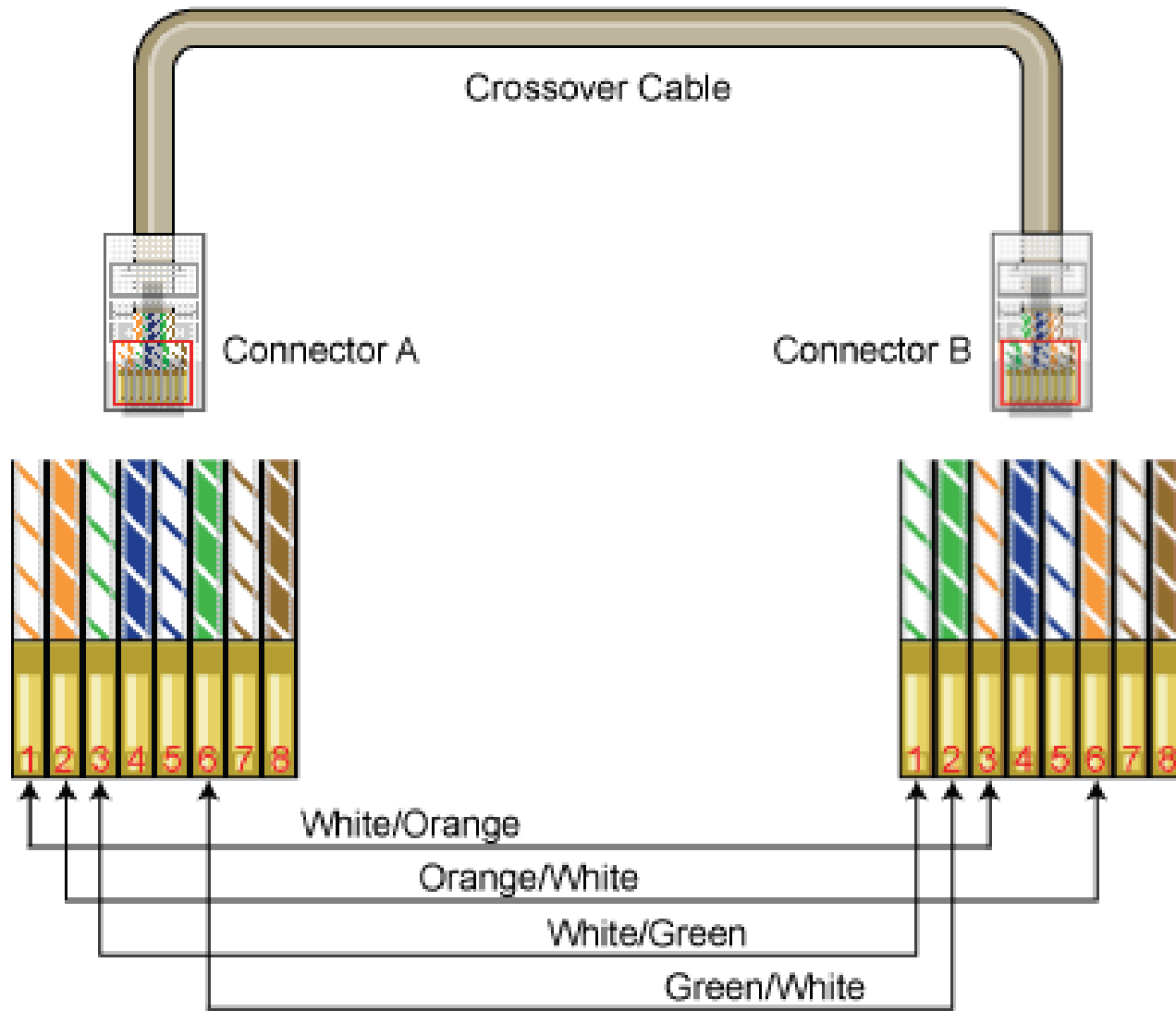

Topical Networking Setup

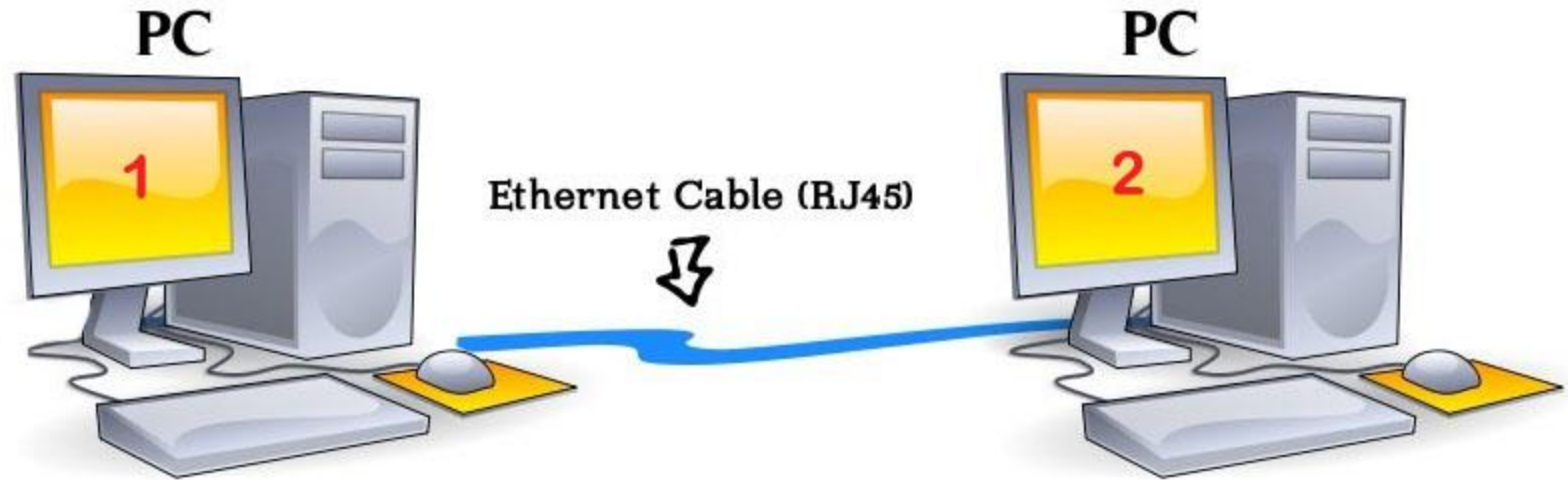

PC-1	
IP address	192.168.0.1
Subnet Mask	255.255.255.0
Default Getaway	N/A

PC-2	
IP address	192.168.0.2
Subnet Mask	255.255.255.0
Default Getaway	192.168.0.1

PC Configure Setup

select **Internet Protocol Version 4 (TCP/IPv4)** and click on the Properties or Double-click on it.

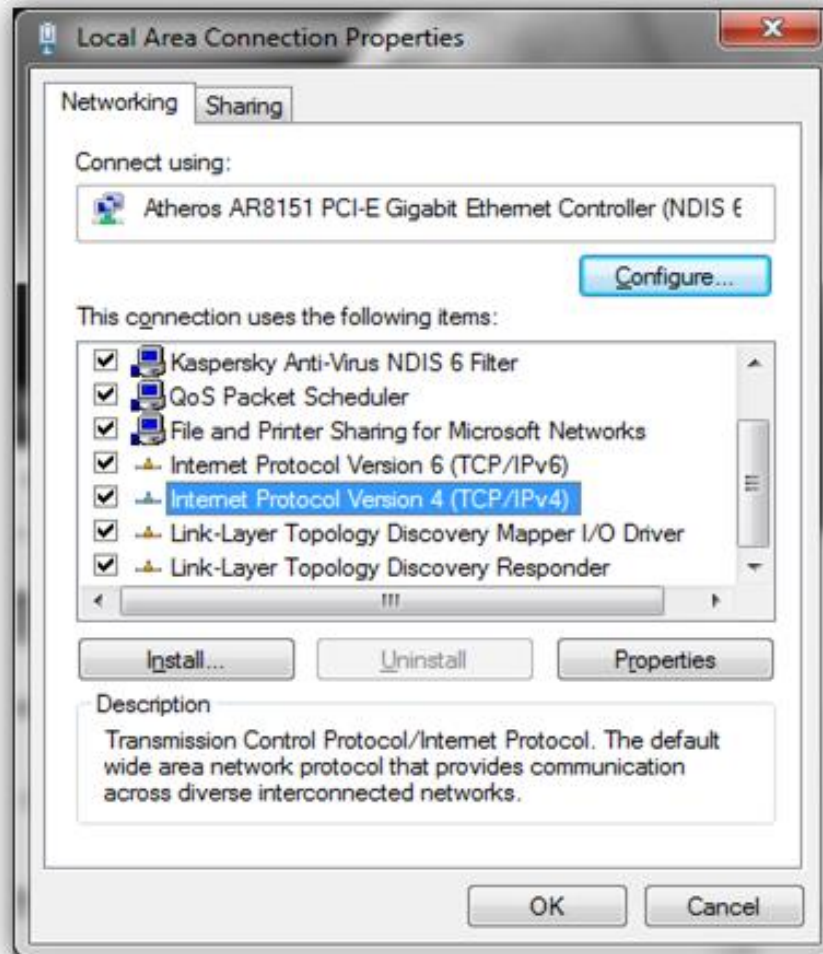

PC Configure Setup

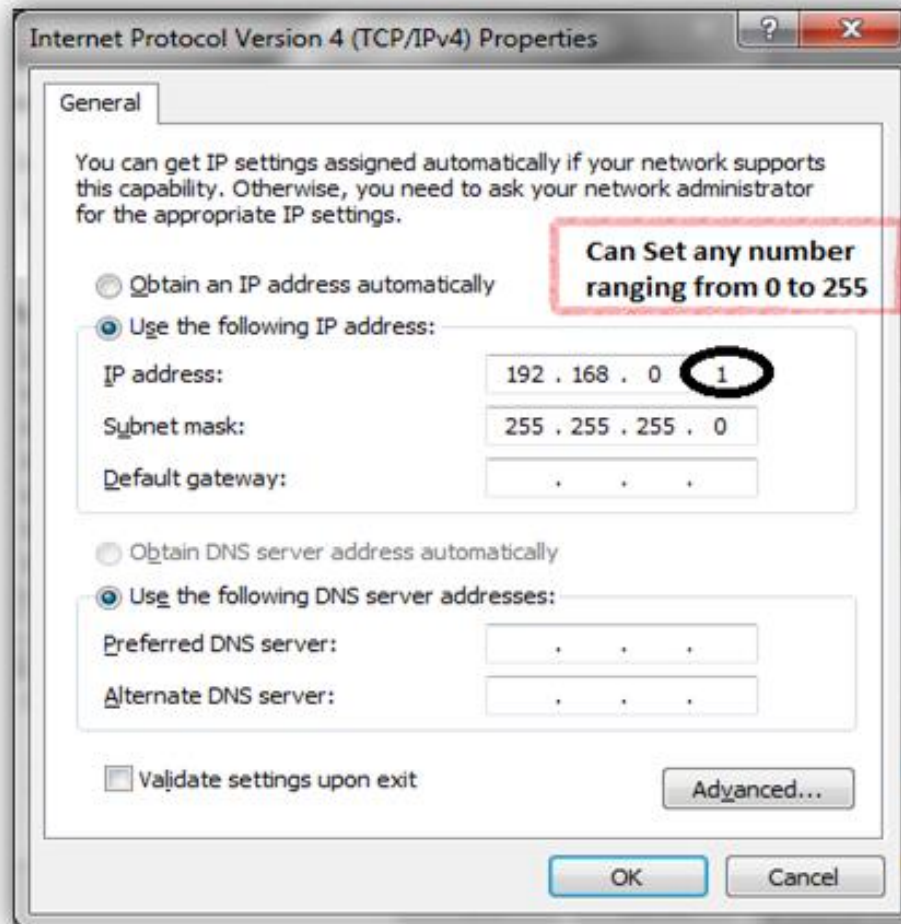

PC Configure Setup

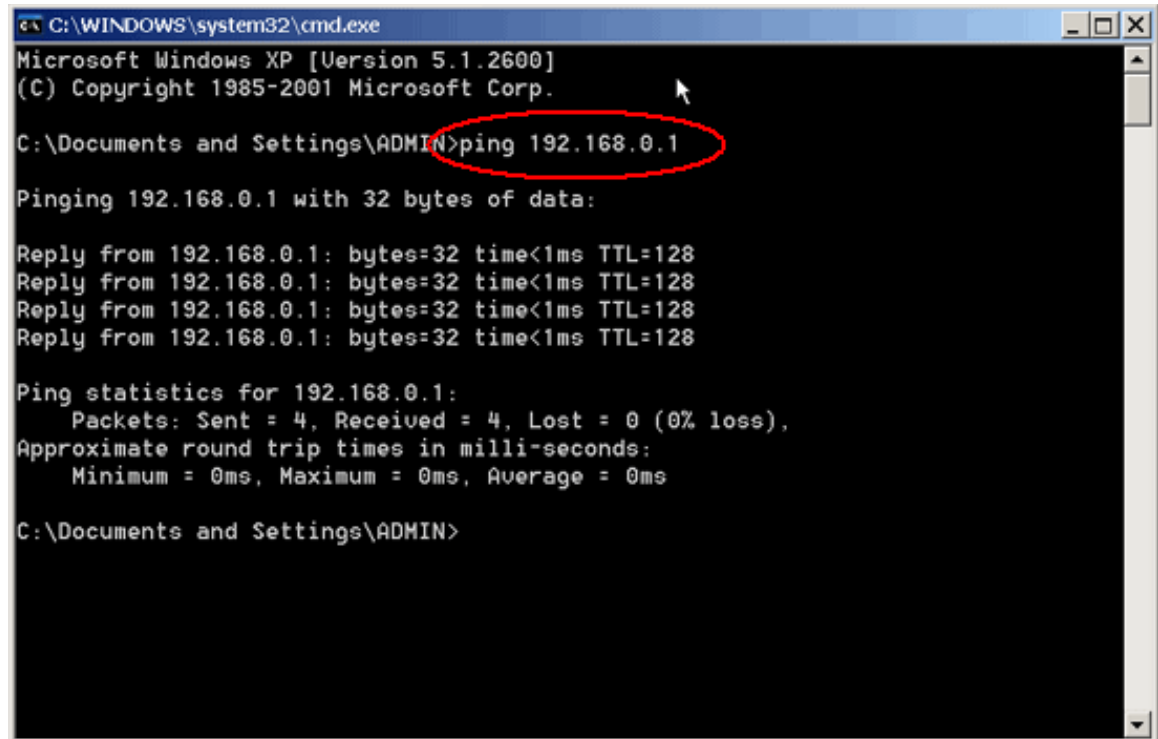
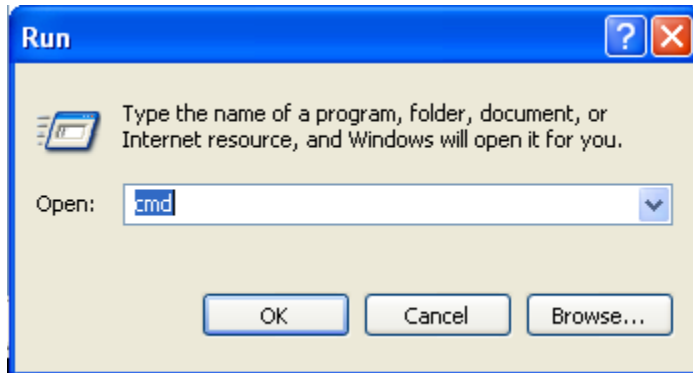

```
C:\WINDOWS\system32\cmd.exe
Microsoft Windows XP [Version 5.1.2600]
(C) Copyright 1985-2001 Microsoft Corp.

C:\Documents and Settings\ADMIN>ping 192.168.0.1

Pinging 192.168.0.1 with 32 bytes of data:

Reply from 192.168.0.1: bytes=32 time<1ms TTL=128
Reply from 192.168.0.1: bytes=32 time<1ms TTL=128
Reply from 192.168.0.1: bytes=32 time<1ms TTL=128
Reply from 192.168.0.1: bytes=32 time<1ms TTL=128

Ping statistics for 192.168.0.1:
    Packets: Sent = 4, Received = 4, Lost = 0 (0% loss),
    Approximate round trip times in milli-seconds:
        Minimum = 0ms, Maximum = 0ms, Average = 0ms

C:\Documents and Settings\ADMIN>
```

Introduction to IP addressing

- Each Network Interface Card (NIC or Network card) present in a PC is assigned one Network address called as IP address [or Network address].
- This IP address is assigned by the administrator of the network. No two PCs can have the same IP address.
- There is a burned-in address on the NIC called as Physical Address

Format of IP address

- IPv4 is made up of four parts, in the pattern as w.x.y.z.
- Each part has 8 binary bits and the values in decimal can range from 0 to 255.

IP address classes

IP address class	Value of the leftmost byte
Class A	1-126 [0 and 127 are not allowed]
Class B	128-191
Class C	192-223

Grouping of IP addresses into different classes.

Class A, B, C, D, E

- Class A: first bit in w is 0 and others can be anything :
 - i. 0.0.0.0 to 127.255.255.255
 - ii. First bits are used for network part and the remaining for host part.

Class B

First bit in w is 1 and second bit is 0.

- i. 128.0.0.0 to 191.255.255.255
- ii. First 16 bits for network part and remaining host part

Class C

first bit in w is 1, second bit in w is 1 and third bit is 0

- i. 192.0.0.0 to 223.255.255.255
- ii. First 24 bits for network part and last 8 bits for host part.

Class D

first, second, third bits in w are 1 and fourth bit is 0; used for multicast.

- i. 224.0.0.0 to 247.255.255.255

Class E

- future use or experimental purposes.

Default Subnet mask

it is used to identify the network part from the host part. Put binary one for the parts that represent network part and zero for the part that represent host part.

- a. Class A: 255.0.0.0
- b. Class B: 255.255.0.0
- c. Class C: 255.255.255.0
- d. We can't have mix of 1s and 0s in subnet mask. Only consecutive 1s is followed by consecutive 0s

LAN Connection

- PC to PC – cross
- PC to Switch – straight
- Switch to Switch - cross

Thank you!!!